

APPLICATION

The paddle type SPDT HFS series are designed to provide excellent performance where accuracy, reliability, and rugged construction (IP54) are required used in liquid flow lines carrying water or any fluid neither harmful to brass and phosphor bronze nor classified as a hazardous fluids.

They can be wired to close one circuit and open a second circuit when liquid flow either exceeds or drops below the adjusted flow rate.

The HFS series are recommended for liquid pressure and temperature as mentioned below and must not be used on lines carrying liquids below 0 degree C.

These series may be used on liquids with high salt or chlorine content but is not for use in hazardous atmospheres.

They may be also used outdoors but must be protected from weather or splashing water.

All series HFS flow switches are designed for use only as operating controls.

Where an operating control failure would result in personal injury and/or loss of property, it is the responsibility of user to add safety devices that protect against, or supervisory systems that warn of control failure.



White ABS Cover
Stainless Steel Base Plate

RoHS

SPECIFICATION

Operating Pressure	10kgf/cm ² (1MPa)
Withstand Pressure	17.5Kgf/cm ² (1.75MPa)
Insulation Resistance	Over 100Ω, DC500VM
Withstand Voltage	AC1500V/1minute
Contact Point Life	1000K Cycle
Bellows Life	500K Cycle
Temperature of Fluid	Max 100°C (212°F)

ELECTRICAL RATINGS

Type	Voltage	Resistance Load	Lamp Load	Motor Load
AC (Standard)	AC 125 V AC 250 V	5A 2.5A	44A 22A	5A 2.5A
DC	DC 115 V DC 230 V	0.3A 0.15A		

DIMENSION

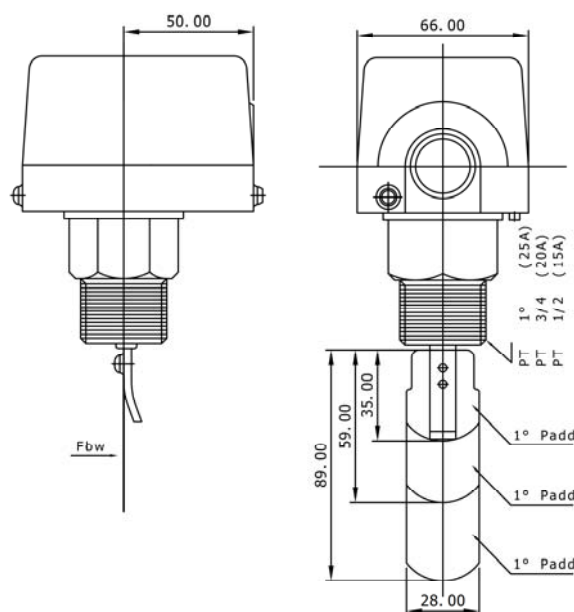

This product meets the requirements of **CE**

FLOW CONTROL RANGE TABLE

CLASSIFICATION		FLOW CONTROL RANGE		LPM (GPM)	
Pipe Diameter (inch)	Paddle	Minimum		Maximum	
		On-Flow	Off-Flow	On-Flow	Off-Flow
1	1	15 (4.0)	8 (2.0)	45 (12.0)	41 (11.0)
1-1/4		26 (6.9)	13 (3.4)	75 (20.0)	68 (18.0)
1-1/2		29 (7.0)	20 (5.3)	105 (28.0)	94 (25.0)
2	2	34 (9.0)	17 (4.5)	120 (32.0)	105 (28.0)
2-1/2		60 (16.0)	34 (9.0)	210 (55.0)	188 (50.0)
3	3	68 (18.0)	30 (8.0)	288 (76.0)	275 (73.0)
4		128 (34.0)	64 (17.0)	412 (109.0)	360 (95.0)
5		225 (59.0)	113 (30.0)	750 (198.0)	652 (172.0)
6		345 (91.0)	172 (45.0)	1125 (297.0)	975 (258.0)

*This table illustrates the flow control range obtained from experimental data. A variation of up to 10% can be expected, depending on operating conditions. Final adjustments should be made on site using a flow meter

PRESSURE LOSS RATE

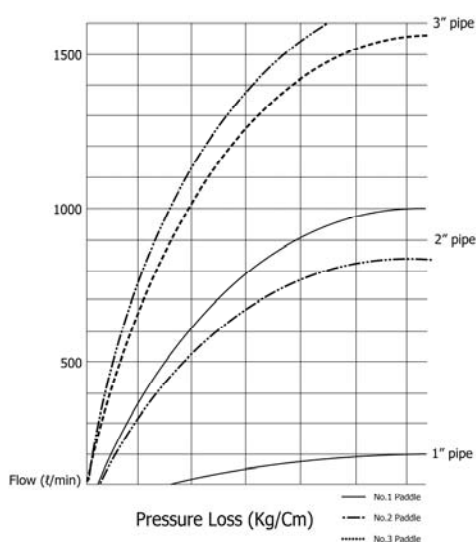

FLOW-VELOCITY

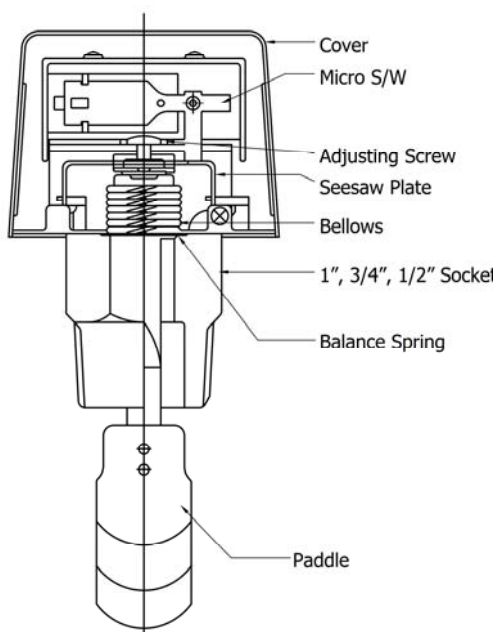
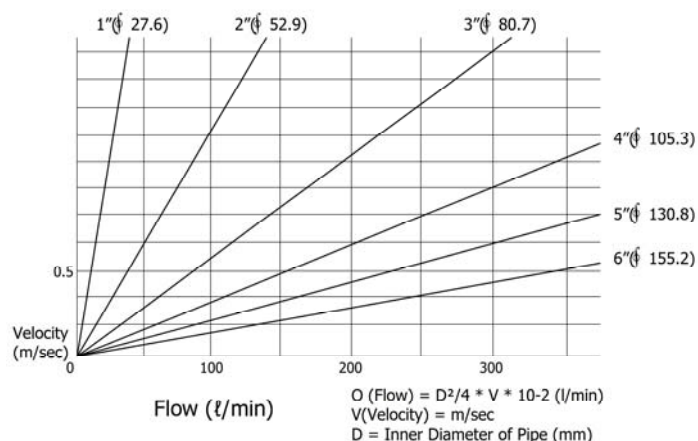

Typical Installation

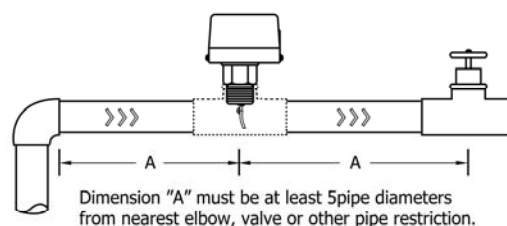

NO-FLOW

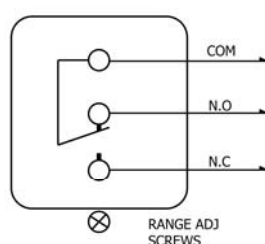

FLOW

