

Damper actuator for operating air control dampers in ventilation and air-conditioning systems for building services installations

- Torque 4 Nm
- Nominal voltage AC/DC 24 V
- Control Open/close (not made for 3-point applications)
- Running time 2.5 s

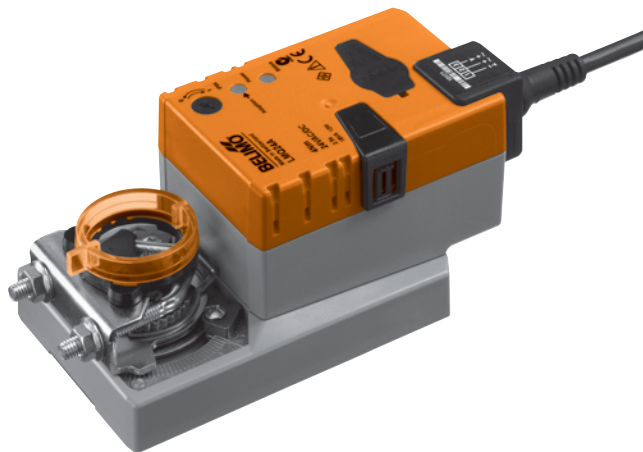

Technical data

Electrical data	Nominal voltage	AC 24 V, 50/60 Hz / DC 24 V
	Nominal voltage range	AC 19.2 ... 28.8 V / DC 21.6 ... 28.8 V
	Power consumption	In operation 13 W @ nominal torque At rest 1.5 W For wire sizing 23 VA (I max. 20 A @ 5 ms)
	Connection	Cable 1 m, 3 x 0.75 mm ²
Functional data	Torque (nominal torque)	Min. 4 Nm @ nominal voltage
	Direction of rotation	Reversible with switch 0 ↻ or ↻ 1
	Manual override	Gearing latch disengaged with push-button, can be locked
	Angle of rotation	Max. 95° ↻, limited on both sides by means of adjustable mechanical end stops
	Running time	2.5 s / 90° ↻
	Automatic adjustment of operating range and measuring signal U to match the mechanical angle of rotation	Manual triggering of the adaption by pressing the «Adaption» button
	Sound power level	52 dB (A)
	Position indication	Mechanical, pluggable
	Negative torque	⚠ ≤50% from nominal torque (Caution: can only be used with restrictions. Please contact your Belimo representative.)
	Safety	Protection class
Degree of protection		IP54 in any mounting position, UL/NEMA 2
EMC		CE according to 2004/108/EC
Certification		cULus according to UL 60730-1A and UL 60730-2-14 and CAN/CSA E60730-1:02 Certified to IEC/EN 60730-1 and IEC/EN 60730-2-14
Mode of operation		Type 1 (EN 60730-1)
Rated impulse voltage		0.8 kV (EN 60730-1)
Control pollution degree		3 (EN 60730-1)
Ambient temperature		-30 ... +40 °C (no restrictions) ⚠ +40 ... +50 °C (Caution: can only be used with restrictions. Please contact your Belimo representative.)
Non-operating temperature		-40 ... +80 °C
Ambient humidity		95% RH, non condensing (EN 60730-1)
Maintenance	Maintenance-free	
Dimensions / Weight	Dimensions	See «Dimensions» on page 3
	Weight	Approx. 850 g





Safety notes



- This actuator is not allowed to be used outside the specified field of application, especially in aircraft or in any other airborne means of transport.
- It may only be installed by suitably trained personnel. All applicable legal or institutional installation regulations must be complied with.
- The device may only be opened at the manufacturer's site. It does not contain any parts that can be replaced or repaired by the user.
- The cable must not be removed from the device.
- Self adaptation is necessary when the system is commissioned and after each adjustment of the angle (press the adaptation pushbutton)
- When calculating the required torque, the specifications supplied by the damper manufacturers (cross section, design, installation site), and the air flow conditions must be observed.
- The device contains electrical and electronic components and is not allowed to be disposed of as household refuse. All locally valid regulations and requirements must be observed.

Product features

Simple direct mounting	Simple direct mounting on the damper spindle with a universal spindle clamp, supplied with an anti-rotation strap to prevent the actuator from rotating.
Manual override	Manual override with push-button possible (the gear is disengaged for as long as the button is pressed or remains locked).
Adjustable angle of rotation	Adjustable angle of rotation with mechanical end stops.
High functional reliability	The actuator is overload-proof, requires no limit switches and automatically stops when the end stop is reached.
Home position	When the supply voltage is switched on for the first time, i.e. at commissioning or after pressing the „gear disengagement“ switch, the actuator moves to the home position.

Pos. Direction of rotation switch	Home position
 Y = 0  Y = 1 	ccw  Left stop cw  Right stop

The actuator then moves into the position defined by the control signal.

Accessories

	Description	Data sheet
Electrical accessories	Auxiliary switch S..A..	S..A..
	Feedback potentiometer P..A..	P..A..
Mechanical accessories	Various accessories (clamps, shaft extensions etc.)	Z-NM..A..

Electrical installation

Wiring diagrams

Note

- Connect via safety isolation transformer.
- Other actuators can be connected in parallel. Note the performance data.





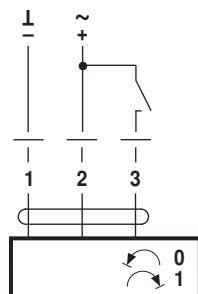



Direction of rotation

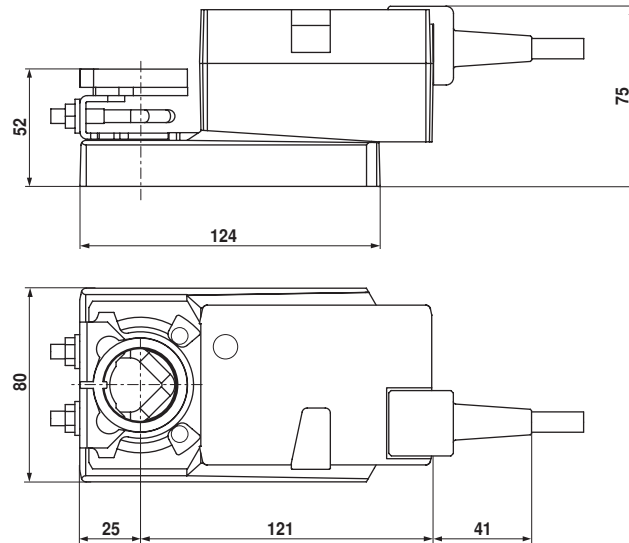

Dimensions [mm]

Dimensional drawings



Damper spindle	Length			
	≥40	8 ... 26.7	≥8	≤26.7
 *	≥20	8 ... 20	≥8	≤20

* Option (accessory K-NA)

Operating controls and indicators

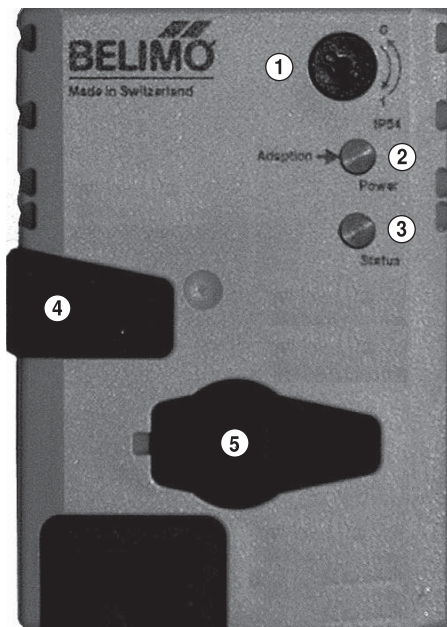

① Direction of rotation switch

Switching over: Direction of rotation changes

② Push-button and green LED display

Off: No voltage supply or fault

On: In operation

Press button: Switches on angle of rotation adaptation followed by standard operation

③ Push-button and yellow LED display

Off: Standard operation

On: Adaptation or synchronising process active

Press button: No function

④ Gear disengagement switch

Press button: Gear disengaged, motor stops, manual override possible

Release button: Gear engaged, synchronisation starts, followed by standard operation

Check voltage supply connection

- a) ② Off and ③ On } Check the supply connections.
 b) ② Blinking and ③ Blinking } Possibly \perp and ∇ are swapped over.

⑤ No function

Modulating damper actuator for operating air control dampers in ventilation and air-conditioning systems for building services installations

- Torque 4 Nm
- Nominal voltage AC/DC 24 V
- Control: modulating DC 2(0) ... 10 V
- Position feedback DC 2 ... 10 V
- Running time 2.5 s

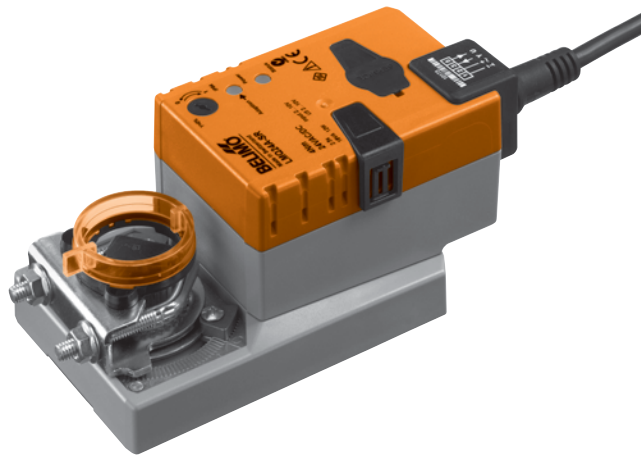
Technical data

Electrical data	Nominal voltage	AC 24 V, 50/60 Hz / DC 24 V
	Nominal voltage range	AC 19.2 ... 28.8 V / DC 21.6 ... 28.8 V
	Power consumption	In operation 13 W @ nominal torque At rest 1.5 W For wire sizing 23 VA (I max. 20 A @ 5 ms)
	Connection	Cable 1 m, 4 x 0.75 mm ²
Functional data	Torque (nominal torque)	Min. 4 Nm @ nominal voltage
	Control signal	DC 2(0) ... 10 V, input impedance 100 kΩ
	Feedback signal	DC 2 ... 10 V, max. 0.5 mA
	Position accuracy	±5%
	Direction of rotation	Reversible with switch 0 / 1
	Direction of motion at Y = 0 V	At switch position 0 ↺ resp. 1 ↻
	Manual override	Gearing latch disengaged with push-button, can be locked
	Angle of rotation	Max. 95° ↔, limited on both sides by means of adjustable mechanical end stops
	Running time	2.5 s / 90° ↔
	Automatic adjustment of operating range and measuring signal U to match the mechanical angle of rotation	Manual triggering of the adaptation by pressing the «Adaptation» button
	Override control	MAX (maximum position) = 100% MIN (minimum position) = 0% ZS (intermediate position, only AC) = 50%
	Sound power level	52 dB (A)
	Position indication	Mechanical, pluggable
	Negative torque	⚠ ≤50% from nominal torque (Caution: can only be used with restrictions. Please contact your Belimo representative.)
Safety	Protection class	III Safety extra-low voltage
	Degree of protection	IP54 in any mounting position, UL/NEMA 2
	EMC	CE according to 2004/108/EC
	Mode of operation	Type 1 (EN 60730-1)
	Certification	cULus according to UL 60730-1A and UL 60730-2-14 and CAN/CSA E60730-1:02 Certified to IEC/EN 60730-1 and IEC/EN 60730-2-14
	Rated impulse voltage	0.8 kV (EN 60730-1)
	Control pollution degree	3 (EN 60730-1)
	Ambient temperature	−30 ... +40°C (no restrictions) ⚠ +40 ... +50°C (Caution: can only be used with restrictions. Please contact your Belimo representative.)
	Non-operating temperature	−40 ... +80°C
	Ambient humidity	95% RH, non condensing (EN 60730-1)
	Maintenance	Maintenance-free
Dimensions / Weight	Dimensions	See «Dimensions» on page 5
	Weight	Approx. 850 g





Safety notes

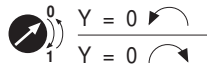

- This actuator is not allowed to be used outside the specified field of application, especially in aircraft or in any other airborne means of transport.
- It may only be installed by suitably trained personnel. Any legal regulations or regulations issued by authorities must be observed during assembly.
- The device may only be opened at the manufacturer's site. It does not contain any parts that can be replaced or repaired by the user.
- The cable must not be removed from the device.
- Self adaptation is necessary when the system is commissioned and after each adjustment of the angle (press the adaptation pushbutton)
- When calculating the required torque, the specifications supplied by the damper manufacturers (cross section, design, installation site), and the air flow conditions must be observed.
- The device contains electrical and electronic components and is not allowed to be disposed of as household refuse. All locally valid regulations and requirements must be observed.

Product features

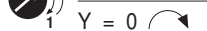
Mode of operation	The drive is actuated with a standard modulating signal DC 2(0) ... 10 V and travels to the position defined by the control signal. The measuring voltage U serves for the electrical display of the damper position 0 ... 100% and as slave control signal for other actuators.
Simple direct mounting	Simple direct mounting on the damper spindle with a universal spindle clamp, supplied with an anti-rotation strap to prevent the actuator from rotating.
Manual override	Manual override with push-button possible (the gear is disengaged for as long as the button is pressed or remains locked).
Adjustable angle of rotation	Adjustable angle of rotation with mechanical end stops.
High functional reliability	The actuator is overload-proof, requires no limit switches and automatically stops when the end stop is reached.
Home position	When the supply voltage is switched on for the first time, i.e. at commissioning or after pressing the „gear disengagement“ switch, the actuator moves to the home position.

Pos. Direction of rotation switch	Home position
 Y = 0	 Left stop
 Y = 0	 Right stop

The actuator then moves into the position defined by the control signal.

Accessories

	Description	Data sheet
Electrical accessories	Auxiliary switch S..A..	S..A..
	Feedback potentiometer P..A..	P..A..
	Positioner SG..24	SG..24
	Range controller SBG24	SBG24
	Room temperature controller CR24-..	CR24-..
	Digital position indication ZAD24	ZAD24
Mechanical accessories	Various accessories (clamps, shaft extensions etc.)	Z-NM..A..

Electrical installation

Wiring diagram

Note

- Connect via safety isolation transformer.
- Other actuators can be connected in parallel. Note the performance data.

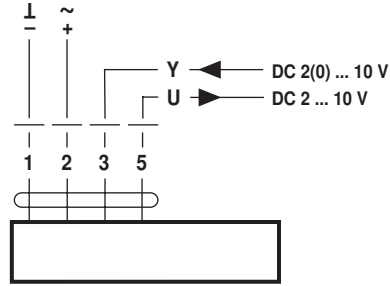

Cable lengths

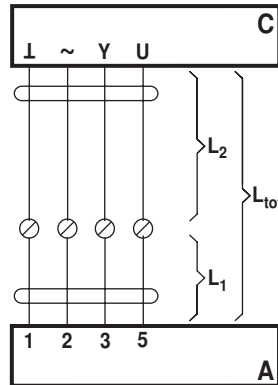

- A = Actuator
- C = Control unit
- L₁ = Belimo connecting cable, 1 m (4 x 0.75 mm²)
- L₂ = Customer cable
- L_{tot} = Maximum cable length

Cross section L ₂ ┆ / ~	max. cable length L _{tot} = L ₁ + L ₂		Example for DC
	AC	DC	
0.75 mm ²	≤ 30 m	≤ 5 m	1 m (L ₁) + 4 m (L ₂)
1.00 mm ²	≤ 40 m	≤ 8 m	1 m (L ₁) + 7 m (L ₂)
1.50 mm ²	≤ 70 m	≤ 12 m	1 m (L ₁) + 11 m (L ₂)
2.50 mm ²	≤ 100 m	≤ 20 m	1 m (L ₁) + 19 m (L ₂)

Note

When several actuators are connected in parallel, the maximum cable length must be divided by the number of actuators.

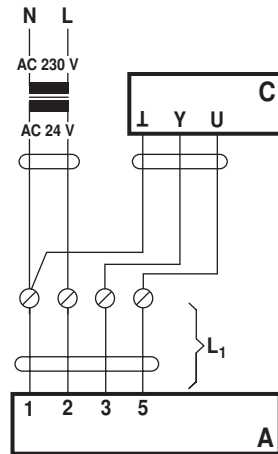

- A = Actuator
- C = Control unit
- L₁ = Belimo connecting cable, 1 m (4 x 0.75 mm²)

Note

There are no special restrictions on installation if the supply and data cable are routed separately

Functions with basic values

Override control with AC 24 V with relay contacts

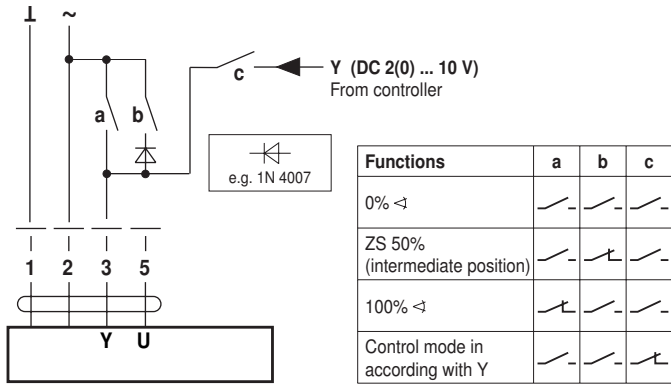

Override control with AC 24 V with rotary control switch

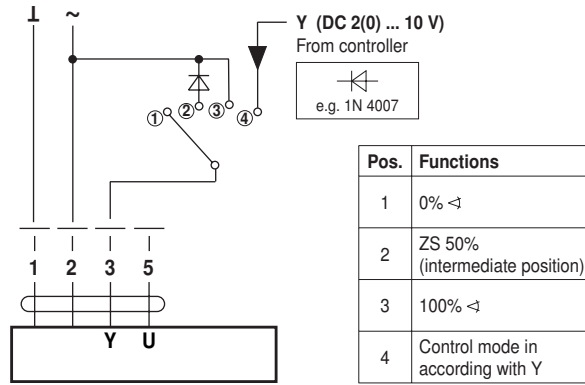

Remote control 0 ... 100 %

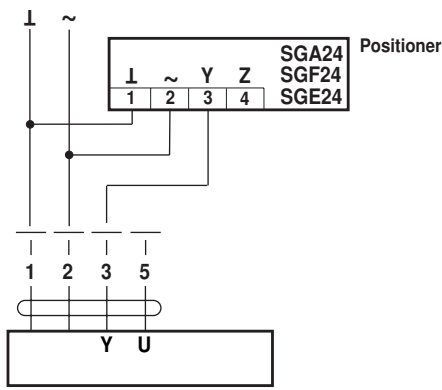

Minimum limit

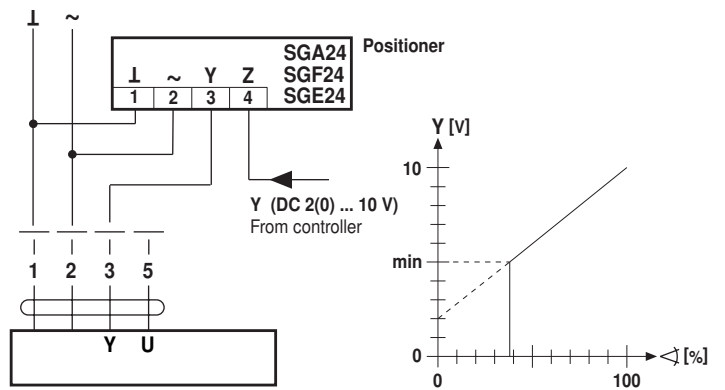

Master/Slave control (position-dependent)

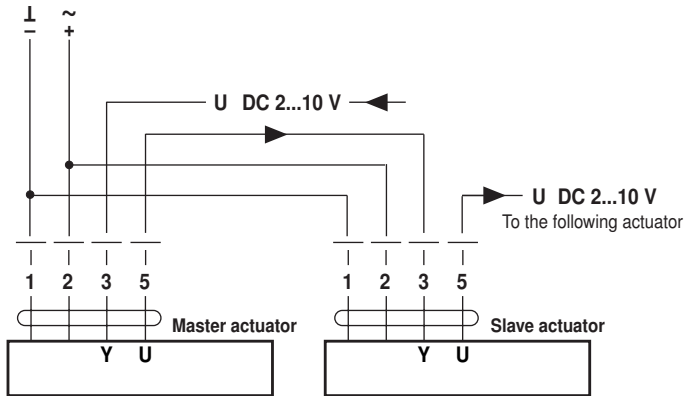

Control with 4 ... 20 mA via external resistance

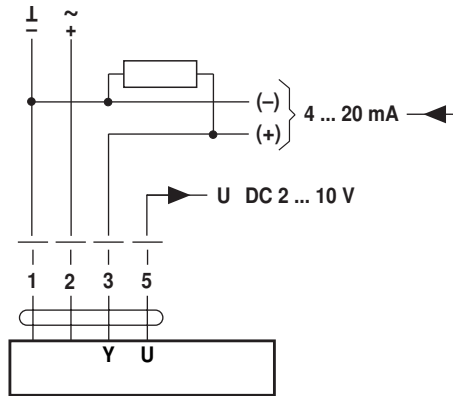

The 500 Ω resistor converts the 4 ... 20 mA current signal into a voltage signal DC 2 ... 10 V

Position indication

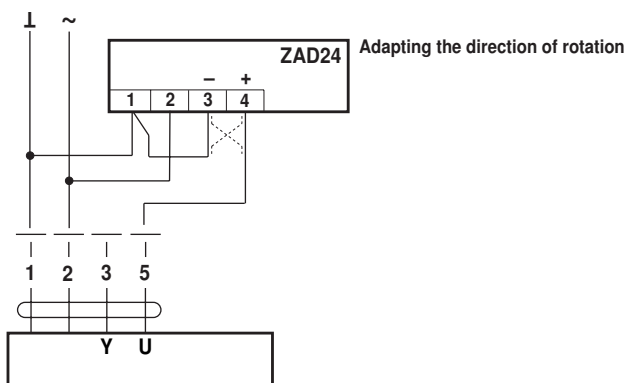

Functional check

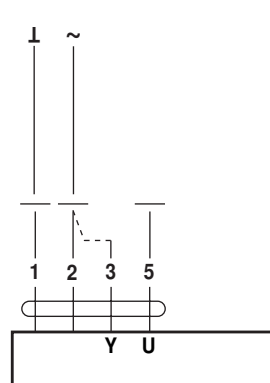

Procedure

- Apply AC 24 V to connection 1 and 2
- Disconnect connection 3:
 - For direction of rotation 0: Actuator turns in the direction of ↻
 - For direction of rotation 1: Actuator turns in the direction of ↻
- Short circuit connections 2 and 3:
 - Actuator runs in the opposite direction

Functions for actuators with specific parameters

Override control and limiting with AC 24 V with relay contacts

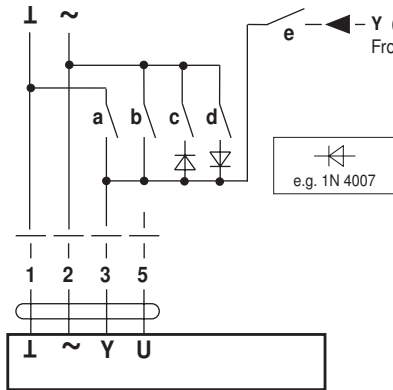

Functions	a	b	c	d	e
CLOSE ¹⁾	—	—	—	—	—
MIN	—	—	—	—	—
ZS (intermediate position)	—	—	—	—	—
MAX	—	—	—	—	—
OPEN	—	—	—	—	—
Control mode in according with Y	—	—	—	—	—

Override control and limiting with AC 24 V with rotary switch

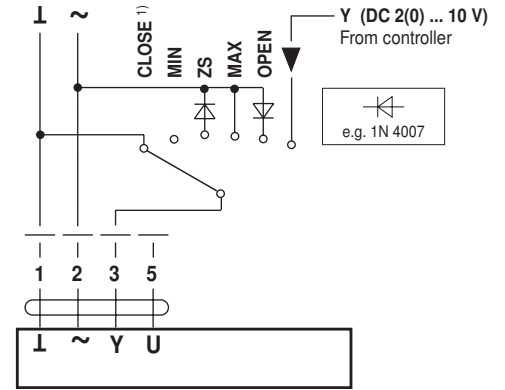

¹⁾ **Caution!** This function is only guaranteed if the start point of the operating range is defined as min. 0.6 V.

Open-close control

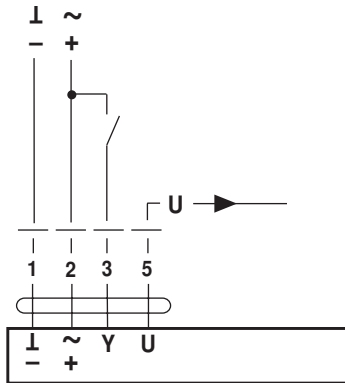

Dimensions [mm]

Dimensional drawings

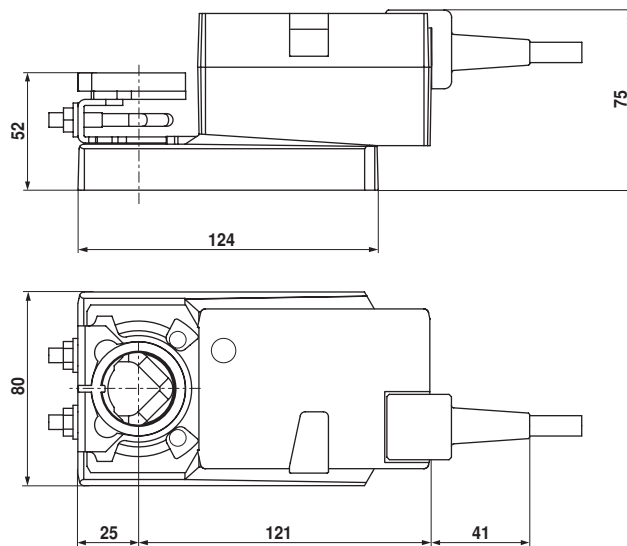

Damper spindle	Length	● I	■ I	◆ I
	≥40	8 ... 26.7	≥8	≤26.7
	≥20	8 ... 20	≥8	≤20

* Option (accessory K-NA)

Operating controls and indicators

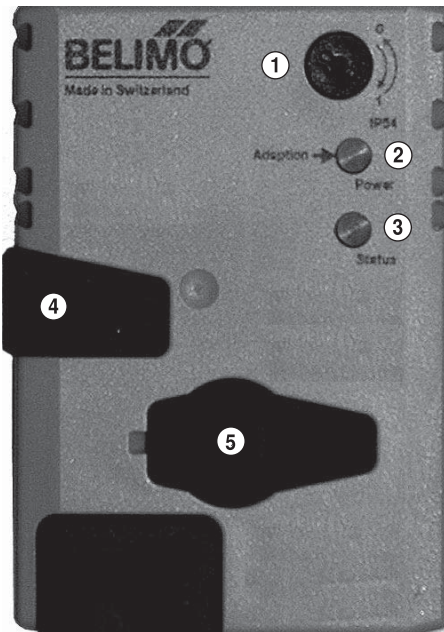
① **Direction of rotation switch**

Switching over: Direction of rotation changes

② **Push-button and green LED display**

Off: No voltage supply or fault

On: In operation

Press button: Switches on angle of rotation adaptation followed by standard operation

③ **Push-button and yellow LED display**

Off: Standard operation

On: Adaptation or synchronising process active

Press button: No function

④ **Gear disengagement switch**

Press button: Gear disengaged, motor stops, manual override possible

Release button: Gear engaged, synchronisation starts, followed by standard operation

Check voltage supply connection

- | | | |
|----|---------------------------|--|
| a) | ② Off and ③ On | } Check the supply connections.
Possibly \pm and $\bar{\tau}$ are swapped over. |
| b) | ② Blinking and ③ Blinking | |

⑤ **No function**