

PRESSURE TRANSMITTER

▶ MODEL : SP100-S

SP100-S 압력트랜스미터는 게이지압 또는 절대압을 측정할 수 있으며, 물과 기름, 가스 등의 압력을 정밀측정 합니다. 측정된 압력값은 Analog 신호로 제공되며, 압력센서는 세라믹 센서를 적용하여 내구성이 강하고 소형이므로 설치가 간편합니다.

Pressure transmitter is designed to measure gauge and absolute pressure in liquids, steam and gases. The measuring device utilizes an thin-film strain gauge. The pressure is converted into an industrial standard electrical signal. It is recommend siphon tube for steam service application as option



● Features

- Cost effective
- High accurate
- Current output
- Light weight
- Wide applications

● Specifications

Supply voltage	24VC (18-30VDC)
Accuracy	±1% FS
Non-linearity	±0.25% FS
Hysteresis	0.5% FS
Stability	0.5% FS/year
Output	4-20mA, 800Ω max
Measuring Range	0-5, 10, 30kgf/cm ²

● Applications

- HVAC equipment
- Industrial equipment
- Compressor control
- Hydraulic system
- Process and refrigeration system

Temperature range	
Operating	-10 to 70°C
Storage	-40 to 70°C
Connections	
Pressuree	3/8" NPT
Electrical	1/2" Cable entries
Warranty	2 years

● Dimensions

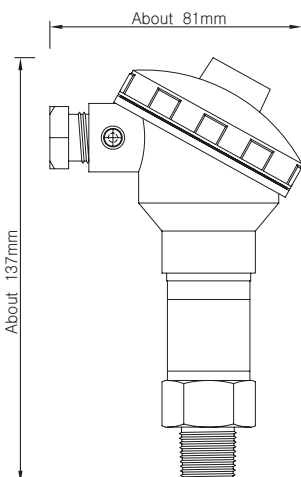

● Wiring

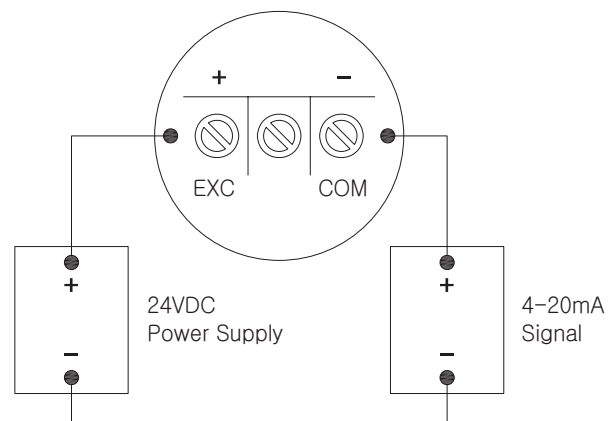

Pipe Sipone (SUS)

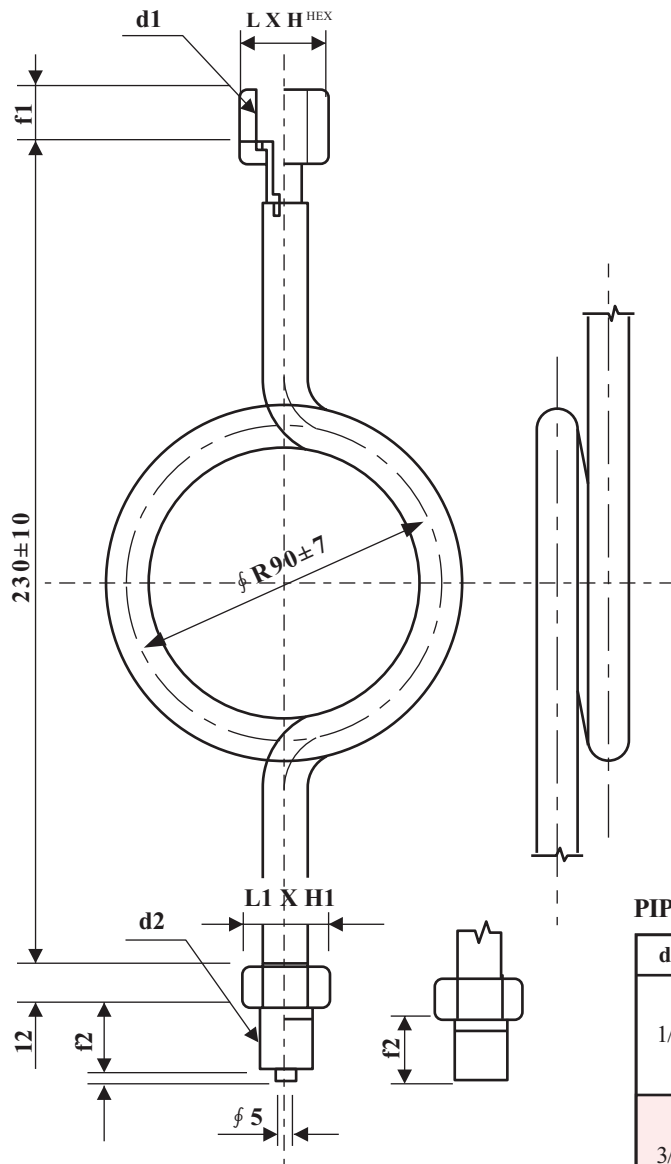

PIPE SIZE 1/2B

d1	f1	L X H	d2	f2	L1 X H1
1/4	13	19 X 22	1/4	16	19 X 22
			3/8	18	22 X 25.4
			1/2	20	26 X 30
3/8	15	22 X 25.4	1/4	16	19 X 22
			3/8	18	22 X 25.4
			1/2	20	26 X 30
1/2	17	26 X 30	1/4	16	19 X 22
			3/8	18	22 X 25.4
			1/2	20	26 X 30