

DIFFERENTIAL PRESSURE TRANSMITTER

▶ MODEL : DP282

DP282 차압트랜스미터는 물(스팀) 또는 가스의 차압을 측정하는 기기로써, 측정된 압력값은 Analog 신호로 제공되며, Zeroing switch가 내장되어 현장에서 간단히 영점조정이 가능합니다. 압력센서는 세라믹센서를 적용하여 측정값의 신뢰성이 높으며, 내구성이 강하고 소형이므로 설치가 간편합니다.

The DP282 measures differential pressure in liquids and gases compatible with stainless steel.

This unit is suitable for HVAC and process applications including measurement of differential pressure from the coils, heat exchangers, pumps, filters, and liquid level.



● Features

- Low cost
- High accurate
- Analog output
- Light weight
- Wide applications

● Specifications

Supply voltage	24VAC/DC
Accuracy	±1% FS
Non-	±0.25% FS
Warm up time	0.5% FS
	0.5% FS/year
Output	4-20mA, 800Ω max
	0-5, 7, 10 kgf/cm ²

Control relay

● Dimensions

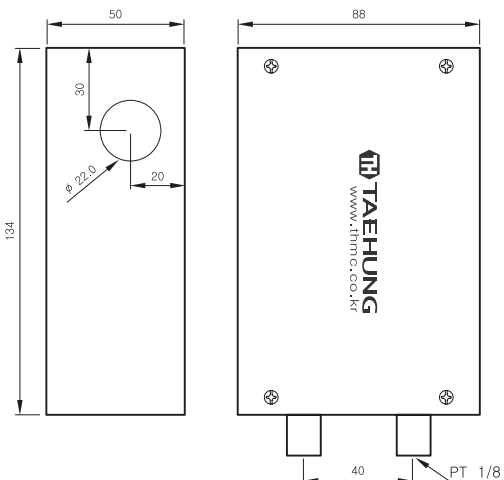

● Applications

- Residence or office buildings :
 - Hotel, exhibition hall, hospital, air port, theater, house, office, meeting room, classroom and etc.
- Green houses
- Breweries

Temperature range

Operating 0-50°C

Storage -20°C to 70°C

Connections

Pressure 1/8" PT

Electrical 22mmΦ Cable entries

Warranty 1 years

● Wiring

