

# 11-4

## 2방 버터플라이 밸브 40A ~ 600A

### 재질 | Material Table |

NO.	PART NAME	MATERIAL	Q'TY
1.	BODY	Cast Iron(FC)	1
2.	DISC	SCS13 / CF8	1
3.	SEAT	EPDM	1
4.	UPPER STEM	SS304	1
5.	LOWER STEM	SS304	1
6.	PACKING	Resin	1
7.	O-RING	EPDM	2
8.	SNAP RING	STEEL	1
9.	TOP PLATE	SS304	1
10.	SCREW BOLT	SS304	2
11.	BOTTOM BOLT	STEEL	1

OPERATOR : ACTUATOR

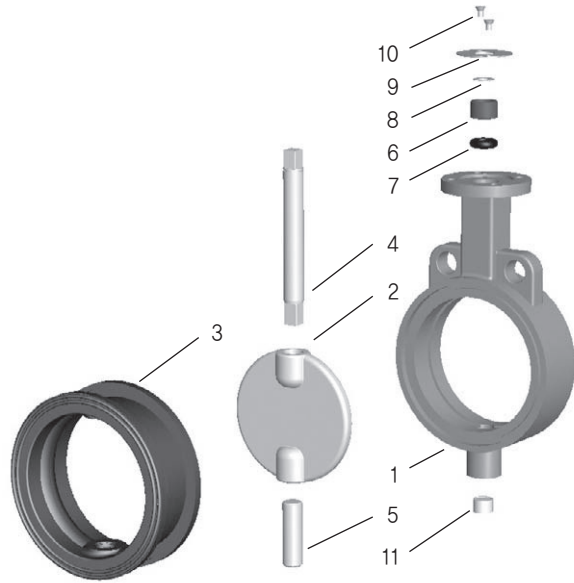

### 페인팅 | Body Painting |

- Color : Blue
- Powder Coating : RAL 5017
- Thickness (Finish coat) : 75~100 microns

### 사양 | Specifications |

- Pressure Rating : JIS 10K, 20K  
PN 10 / 16 / 20, ANSI 150LB
- Face to Face Dimensions : ISO 5752, JIS B2032
- Inspection and Testing : API 598, BS 5155
- Surface Quality Visual Method : MSS-SP-55
- Marking Standard : MSS-SP-25
- Operator : Pneumatic & Electric Actuator

### 표시 | Body Marking |

FRONT	
SIZE	40A~600A
MATERIAL	FC
BACK	
PRESSURE PATING	10K
	150LB
	PN 10 / 16 / 20

외형치수 | Shape Dimension

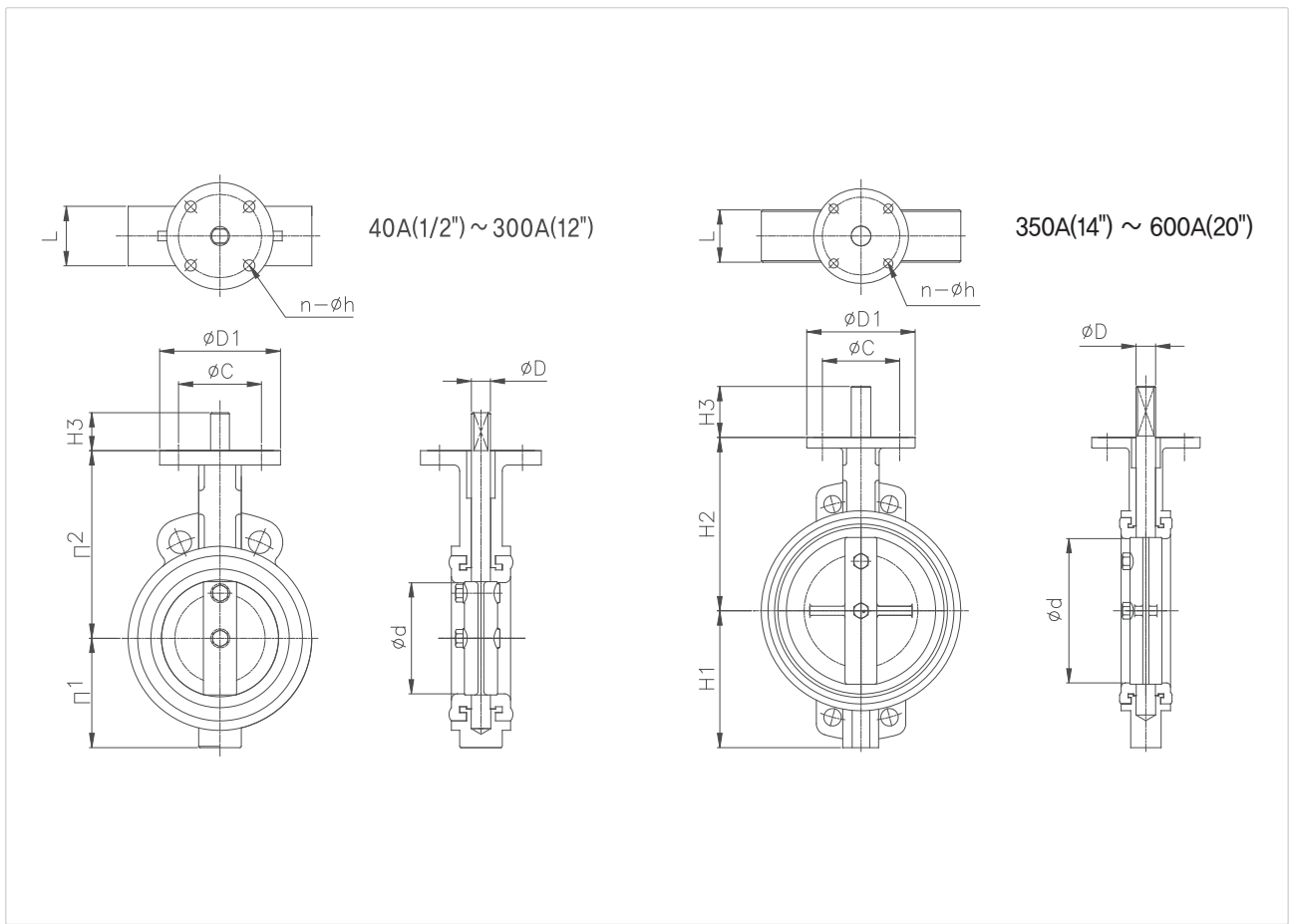

Size		Ød	L	ØD	ØC1	ØD1	n	Øh	H1	H2	H3	Weight(kg)	N.m
mm	inch												
40	1½	40	40	10	70	90	4	9	54	122	35	3.1	15
50	2	52	43	10	70	90	4	9	57	129	35	3.7	19
65	2½	65	46	10	70	90	4	9	67	139	35	4	28
80	3	80	46	10	70	90	4	9	78	156	35	4.4	34
100	4	100	52	12	70	90	4	9	103	164	35	5.9	47
125	5	125	56	15	70	90	4	9	107	187	35	8.9	71
150	6	150	56	15	70	90	4	9	122	200	35	9	108
200	8	198	60	18	70	90	4	9	165	238	35	11	177
250	10	248	68	8x8	102	125	4	12	215	286	45	20	373
300	12	298	78	8x8	102	125	4	12	245	316	45	31.5	490
350	14	327	78	8x8	102	125	4	12	272	345	45	43	-
400	16	387	102	12x8	140	175	4	18	304	382	70	63.5	-
450	18	438	114	12x8	140	175	4	18	333	400	70	99	-
500	20	477	127	14x9	165	230	4	20	370	438	80	114.5	-
550	22	518	154	15x9	165	230	4	20	406	475	80	149.5	-
600	24	560	154	16x10	165	230	4	20	420	510	80	214.5	-